

ERMEST

www.ermest.com

Loading robot

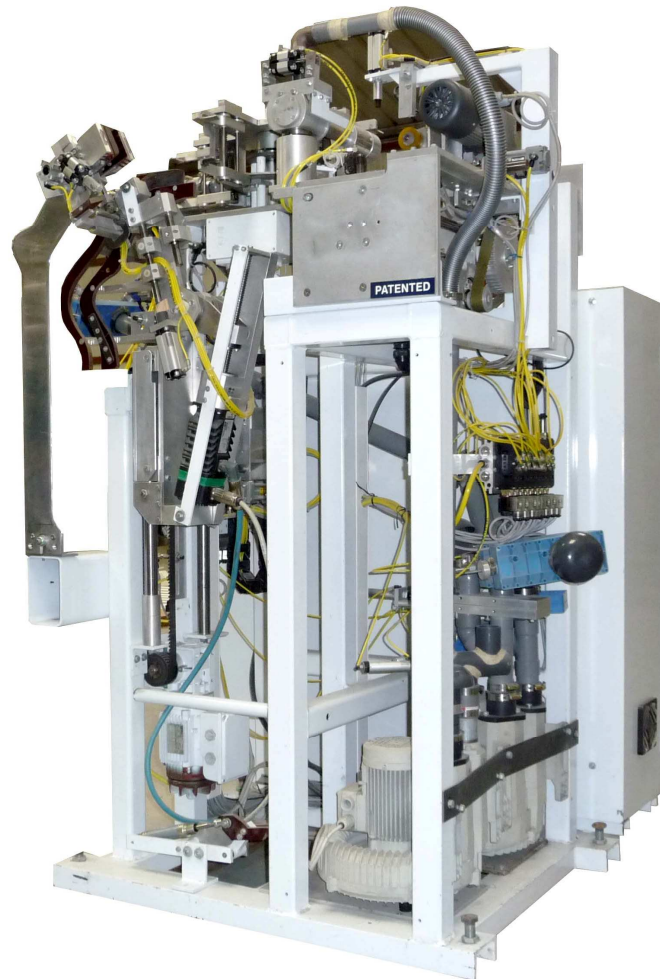

**THE BOARDING
EXPERTS**

**INNOVATIONS
Since 1995**

E.R.M.E.S.T. sarl
rue Jean Colas - Z.I.
10 440 TORVILLIERS (France)
Tél : +33 (0) 3 25 74 34 91
Fax : +33 (0) 3 25 79 55 48
E-mail : ermest@wanadoo.fr

Technical data

The robot enables correct orientation of the socks with automatic loading on form legs

The robot may be fed through:

- a 'pick and place' where the socks are stored in bulk in a container and automatically taken , or

- a toe sewing machine

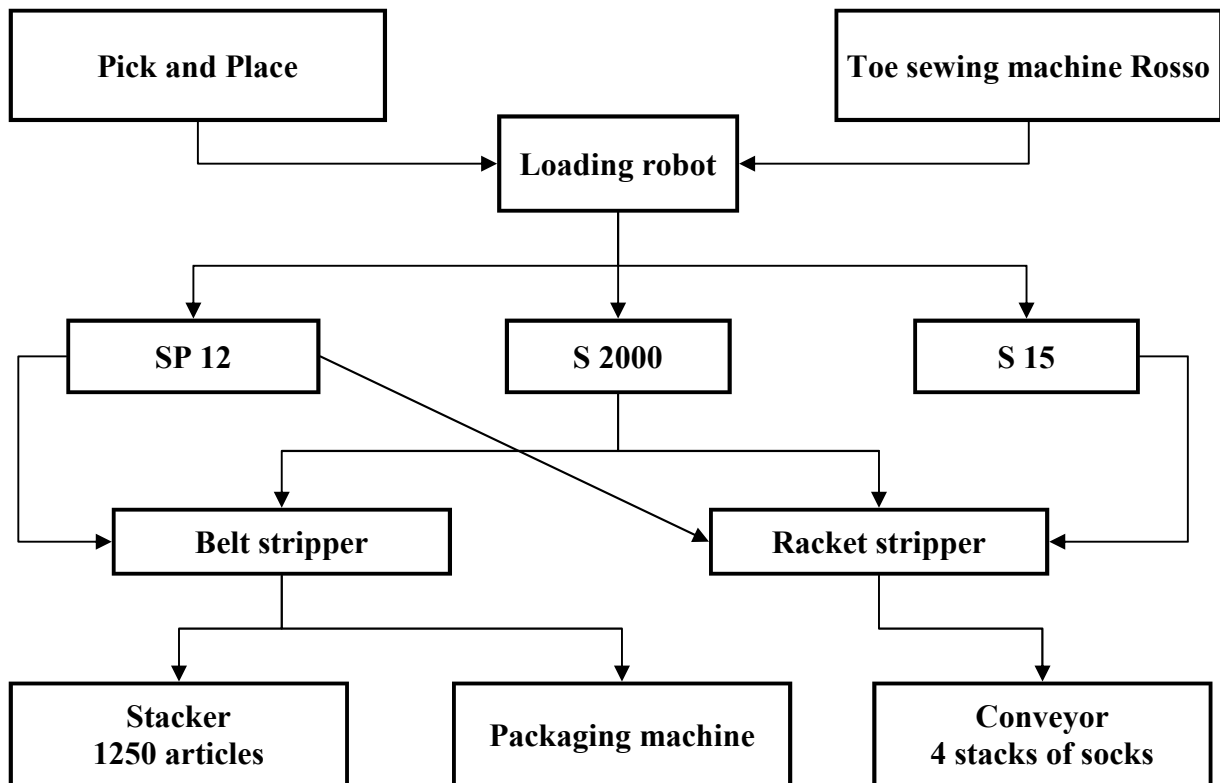

Production : up to 500 pairs per hour

Weight : abt. 400 kg

Indicative consumptions :

- électricity 4 à 12 kW.h
- compressed air 1 à 2 Nm3/h

Optionals

For further optional please contact us

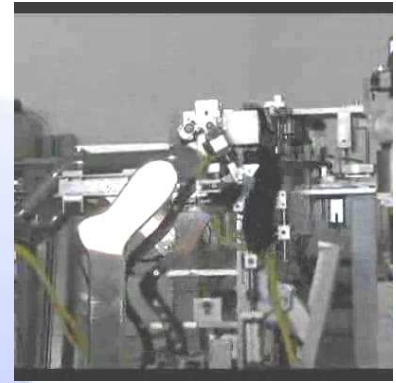

After the orientation stage, the sock is loaded on a form leg with standard shaped foot by the loading arm

The soft motion of the robot keeps with the edges of the form legs so as to avoid excessive tension on the sock

The position of the heel and the length of the leg are ensured by the 'length control' of the machine.

Floor space dimensions

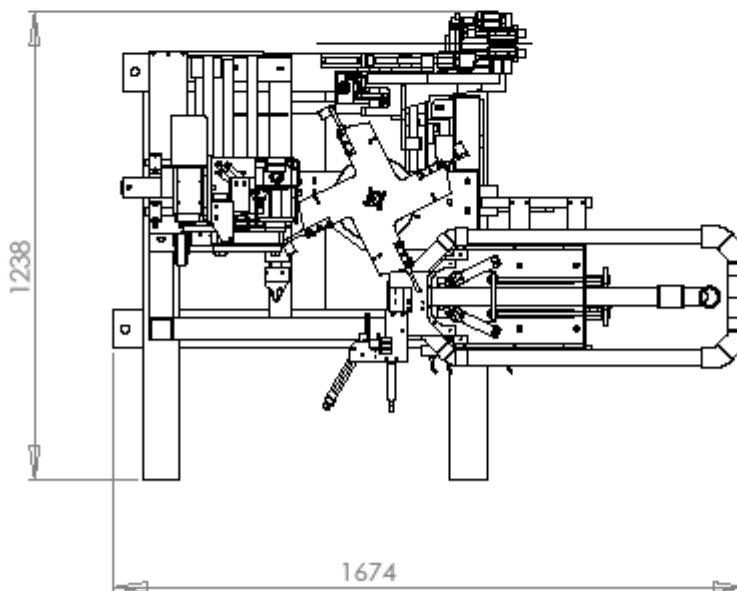
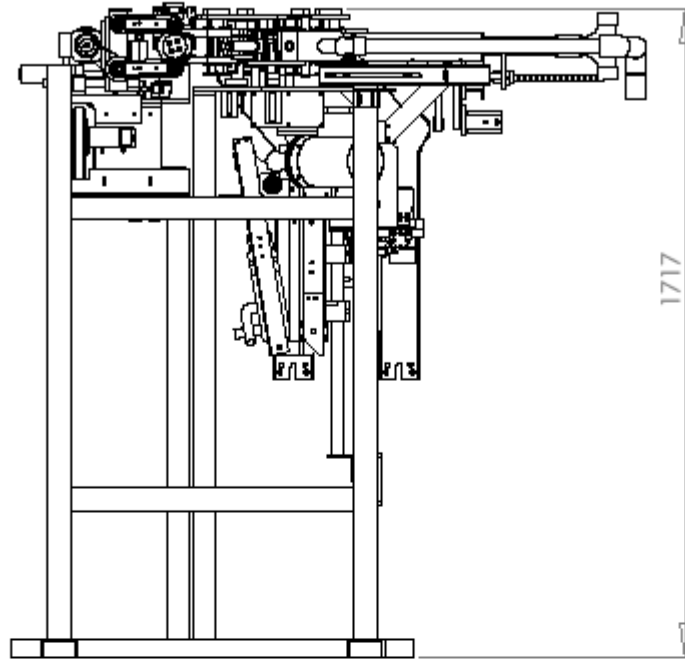

Commissioning on site is carried out by one of our engineers

E.R.M.E.S.T. sarl
rue Jean Colas - Z.I. - 10 440 TORVILLIERS (France)
www.ermest.com e-mail: ermest@wanadoo.fr
Tél : +33 (0) 3 25 74 34 91 - Fax : +33 (0) 3 25 79 55 48