

# ERMEST

[www.ermest.com](http://www.ermest.com)

## SP 12



**NEW**

## THE BOARDING EXPERTS

\*\*\*

### INNOVATIONS Since 1995

E.R.M.E.S.T. sarl  
rue Jean Colas - Z.I.  
10 440 TORVILLIERS (France)  
Tél : +33 (0) 3 25 74 34 91  
Fax : +33 (0) 3 25 79 55 48  
E-mail : [ermest@wanadoo.fr](mailto:ermest@wanadoo.fr)

# Technical data

---

**Capacity: 12 form legs**

**1 steaming press**

**3 heating press positions with a maximum temperature of 180°C (very accurate adjustment of the temperature) and a pressure up to 160 kg per sock (pressure adjustment from 0 to 6 bars).**

**Pressing time adjustable with the timer**

**Press covered with Nomex**

**Automatic stripper and stacking up to 4 stacks on the conveyor**

**Production: up to 500 pairs/h**



**3 optionals available according to the type of steaming**

- A) connection to the existing steam network**
- B) built-in boiler delivered with the machine**
- C) water steaming direct on the press**

**Indicative consumptions:**

- electricity : 5 to 7 kW**
- compressed air : 4 to 6 Nm<sup>3</sup>/h**
- steam : 5 to 10 kg/h (types A & B)**
- water : 5 to 10 litres/h (type C)**

**Easy and quick commissioning by the customer himself**

**The machine may be moved with the help of a pallet truck**

**Weight: abt. 1,200 kg**

**Reduced maintenance and easy to operate**

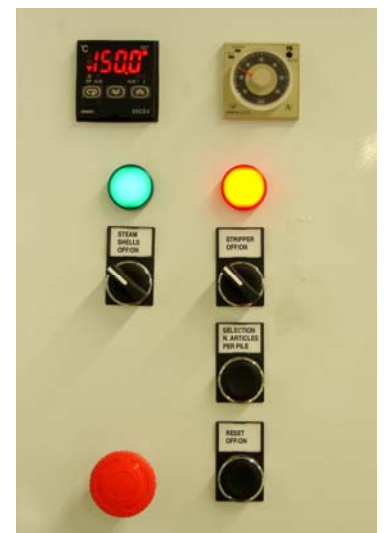

# Optionals

---

**The machine is available with or without stripper**

**The machine is available with a belt stripper enabling to come out direct to a packaging machine or to a stacker with a capacity of 1,250 socks**

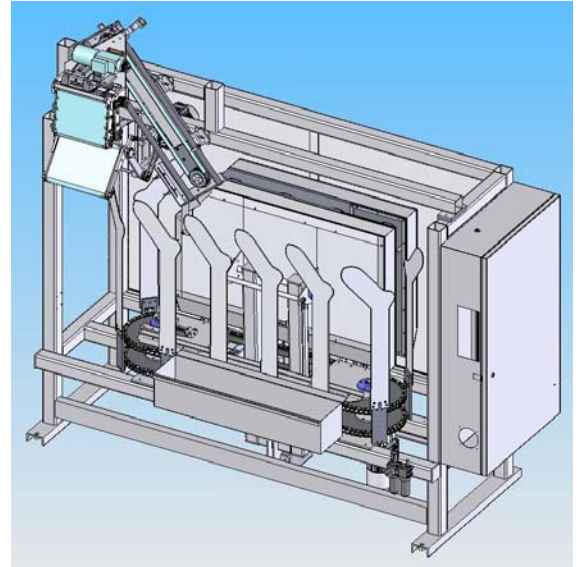

**The machine is available with length control, a double stripper allowing to increase the productivity of the machine up to 600 pairs/h. In this case the machine will be fitted with 14 form legs.**

**Several machines are in operation in the world**

**For any further optional please contact us**

# Floor space dimensions

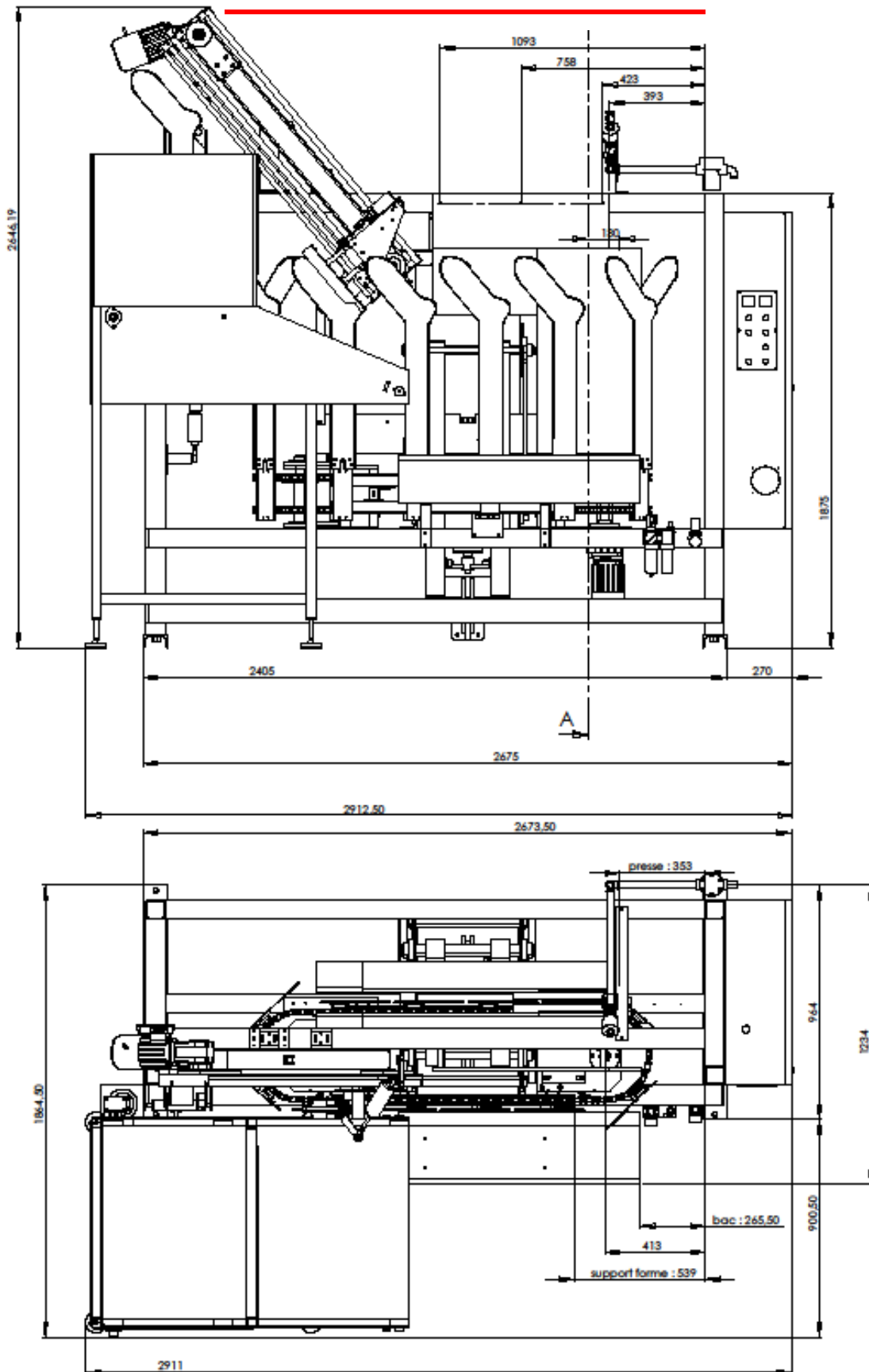

**E.R.M.E.S.T. sarl**  
**Rue Jean Colas - Z.I. - 10 440 TORVILLIERS (France)**  
**[www.ermest.com](http://www.ermest.com) e-mail: [ermest@wanadoo.fr](mailto:ermest@wanadoo.fr)**  
**Tél : +33 (0) 3 25 74 34 91 - Fax : +33 (0) 3 25 79 55 48**